



WALL MOUNT ALL HEATED TOTAL HYDROCARBON ANALYZER MODEL W600



Fully complies with EN 12619, EN 13526 (EU), with 2. BImSchV, 13. BImSchV and 17. BImSchV, and With EPA Method 25A and Method 503 (USA)

Our Wall or HFID Model W600 is a competitively priced, very compact wall or panel mount, self extracting, heated total hydrocarbon FID analyzer for high accuracy, sensitivity and long term stability. The flat design allows to easily install it inside of a certified z-purged cabinet for applications in zoned areas.

The Model W600 uses our time proven hydrogen flame ionization detector (FID) in a heated oven to prevent the loss of high molecular weight hydrocarbons and to provide very reliable performance in the analysis of trace level of contaminants in emissions, gases, air and other gases.

All sample wetted components are mounted in the heated chamber which is accurately kept at 190°C. The heated sample filter is easily accessible from the upper supply panel. No special tools required for a quick and easy sample filter change.

Low cost of ownership. Very low fuel gas consumption. The combustion air supply for the FID-detector is already built in. No external burner air generator or external cylinder for synthetic burner air is needed.

Zero gas and span gas valves and measuring ranges can be operated manually or can be automated by a remote controller.

Features

- Fits easily into a z-purged cabinet to be used in zoned areas.
- All components in contact with sample fully heated and controlled at 190°C
- Built-In air pressure and sample pumps
- Built-in combustion air supply, no extra air bottle needed
- Easy to change sample filter accessible on the rear panel. No special tools required for filter changes
- Separate solenoid valves for zero- and span calibration, standard manual and remote operation
- Automatic flame out alarm
- Pressurized exhaust system for safe extension to waste line
- Optional automatic flame ignition and re-ignition
- Fast response less than 1 second
- Low fuel consumption, no external air consumption
- Remote or automatic measuring range control optional

Applications

- Stack gas or process gas hydrocarbon emissions monitoring
- EPA Method 25A compliance monitoring of source hydrocarbons
- Solvent recovery monitor of carbon bed break through
- Catalytic converter testing
- Carbon adsorption regeneration control
- Raw exhaust vehicle emissions analysis
- Hydrocarbon contamination monitoring in air and other gases
- Carbon adsorption regeneration control
- Detection of trace hydrocarbons in purity gases used in the semi conductor industry
- Clean room applications
- LEL monitor of solvent laden air

The Flame Ionization Detection (FID) method is used to determine the presence of total hydrocarbon concentrations in a gaseous sample. Burning hydrocarbon-free hydrogen in hydrocarbon-free air produces a negligible number of ions.

Once a sample containing hydrocarbons is introduced into this flame a very complex ionization process is started. This process creates a large number of ions. A high polarizing voltage is applied between the two electrodes around the burner nozzle and produces an electrostatic field. Now negative ions migrate to the collector electrode and positive ions migrate to the high voltage electrode. The so generated ionization current between the two electrodes is directly proportional to the hydrocarbon concentration in the sample that is burned by the flame. This signal is measured and amplified by our electrometer-unit.

A sample pressure regulator provides a controlled back pressure at the sample capillary which gives admittance of a constant sample flow rate to the burner. This technique without the conventional back pressure regulator is used by J.U.M. Engineering for over 30 years to provide the highest possible sample flow rate stability and lowest maintenance. Our compactly designed flow control module for controlling the fuel and air flow rates via needle valves use high precision pressure regulators. The needle valves are factory adjusted and sealed to ensure the optimization of the burner.

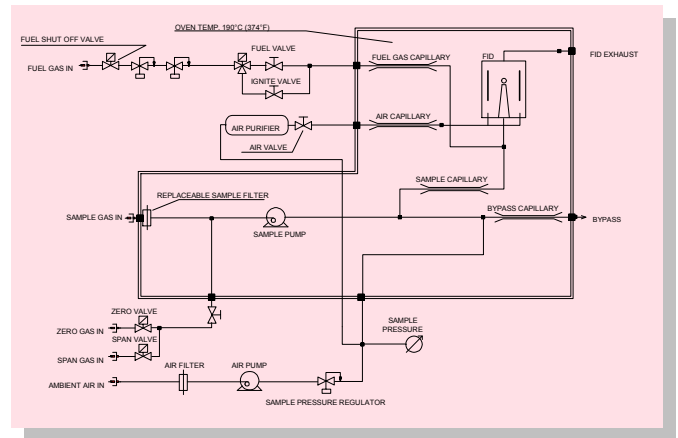

Technical Data	
Method of analysis	Flame Ionization Detector
Sensitivity	Max. 1 ppm CH ₄ full scale
Response time	0.2 seconds
T ₉₀ time	1.2 seconds
T ₉₀ time with heated line (7.5m) and sample filter	less than 8 seconds
Zero drift	<1.0% full scale / 24h
Span drift	<1.0% full scale / 24h
Linearity	Up to 10.000ppm within 1% FSD
Oxygen synergism	< 1.2% FSD
Measuring ranges (ppm)	0-10,100, 1.000, 10.000, 100.000, others on request
Analog outputs	0-10 VDC and 4-20 mA
Display	3 1/2 digit
Sample Filter	2 micron change filter
Sample pump	approx. 2.5 l/min capacity @ operating temp.
Zero and span adjust	Manual on front panel
Fuel consumption 100% H ₂	approx. 20 ml/min @ 1.5 bar (22 psig)
Fuel consumption 40%H ₂ /60%He	approx. 90 ml/min @ 1.5 bar (22 psig)
Burner air consumption	Built in burner air supply
Detector Exhaust	Designed to be extended to waste line or equipped with flame arresor
Oven temperature	190°C (374°F)
Temperature control	µ-processor PID controller
Power requirements	either 230VAC/50Hz, 850 W or 115VAC/60Hz, 850 W
Ambient temperature	5-43°C (41-110°F)
Dimensions (W x D x H)	483 mm x 600 mm x 132 mm
Weight	approx. 20 kg (44 lbs)
J.U.M. reserves the right, at any time and without notice, to change specifications presented in this data sheet and assumes no responsibility for the application or use of the devices described herein.	

Available Options	
AMU 60	Automatic range change
AZM 60	Automatic flame ignition and re-ignition
DCC 60	Dual concentration alarm w. individual adjustable threshold and alarm outputs
ENGA 60	Direct ppm (or other units) 6-digit display, 0-100.000 ppm
FOAS 60	Flame out control with automatic fuel shut off valve
LTO 60	Measurement of low trace hydrocarbon levels. Requires external, zero grade combustion air supply!
PDA 60	Sample pressure monitor with alarm
RCA 60	0-20 mA analog output instead of 4-20 mA
RCC 60	Remote control range change
RC10 60	0-20 mA analog output, galvanically isolated
RC14 60	4-20 mA analog output, galvanically isolated
TPR 60	EXTERNAL temperature controller for heated sample line, e.g. JUM TJ100
Availability of options may change unannounced! Please contact us before specifying your purchase order	



Rear View, Standard Configuration

J.U.M.® Engineering G.m.b.H.
 R&D and Manufacturing
 Gauss-Str. 5
 D-85757 Karlsfeld, Germany
 Tel.: 49-(0)8131-50416, Fax: 49-(0)8131-98894
 E-mail: info@jum.com, Internet: http://www.jum.com

Represented By